

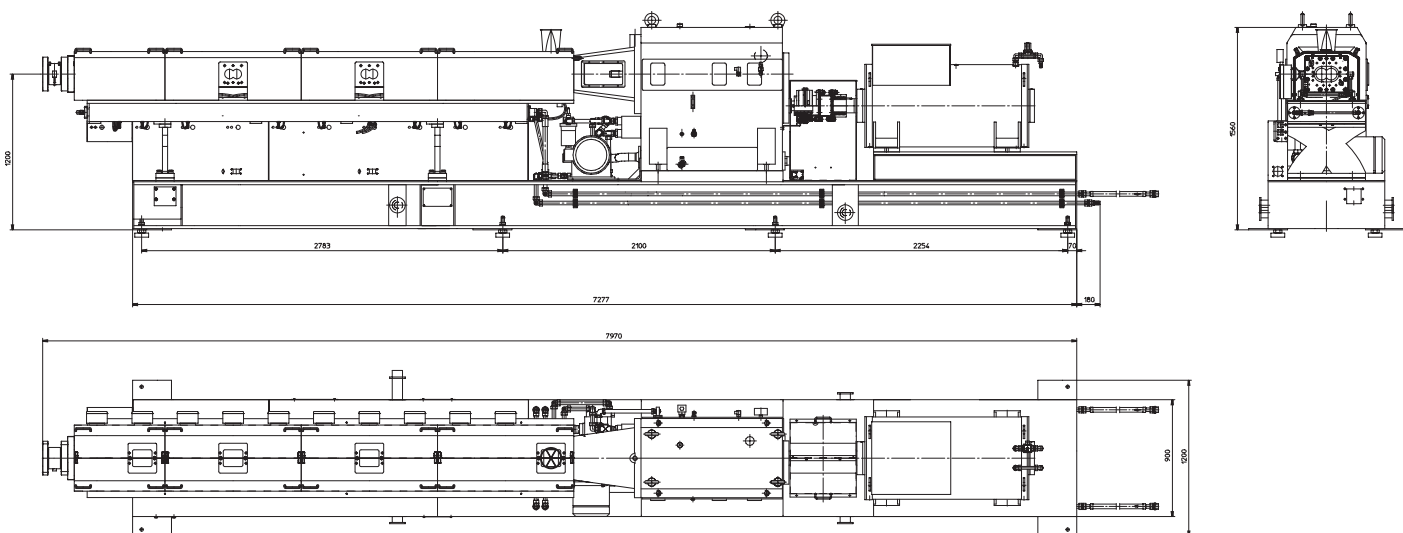

## ➤ Technical data

ZSE 87 MAXX	
Screw diameter (mm)	89.4
Flight depth (mm, without tolerance)	17.6
OD/ID	1.66
maXXstandard-torque (Nm)	8,000
maXXtorque (Nm)	11,432
Screw speed (rpm)	400, 600, 800, 1,000
Weight (kg)	~ 11,500

*\* No responsibility is taken for the correctness of the specifications provided. The specified values depend on the used material type and its consistence as well as on the environmental variables (temperature, humidity etc.) and further factors. Weight and dimensions depend on the processing length (length provided in mm) among other things. If you inform us of your individual demands we will gladly make a binding offer.*



Example of a ZSE 87 MAXX \*

