

EXTRUSION TECHNOLOGY

Extruders & extrusion lines

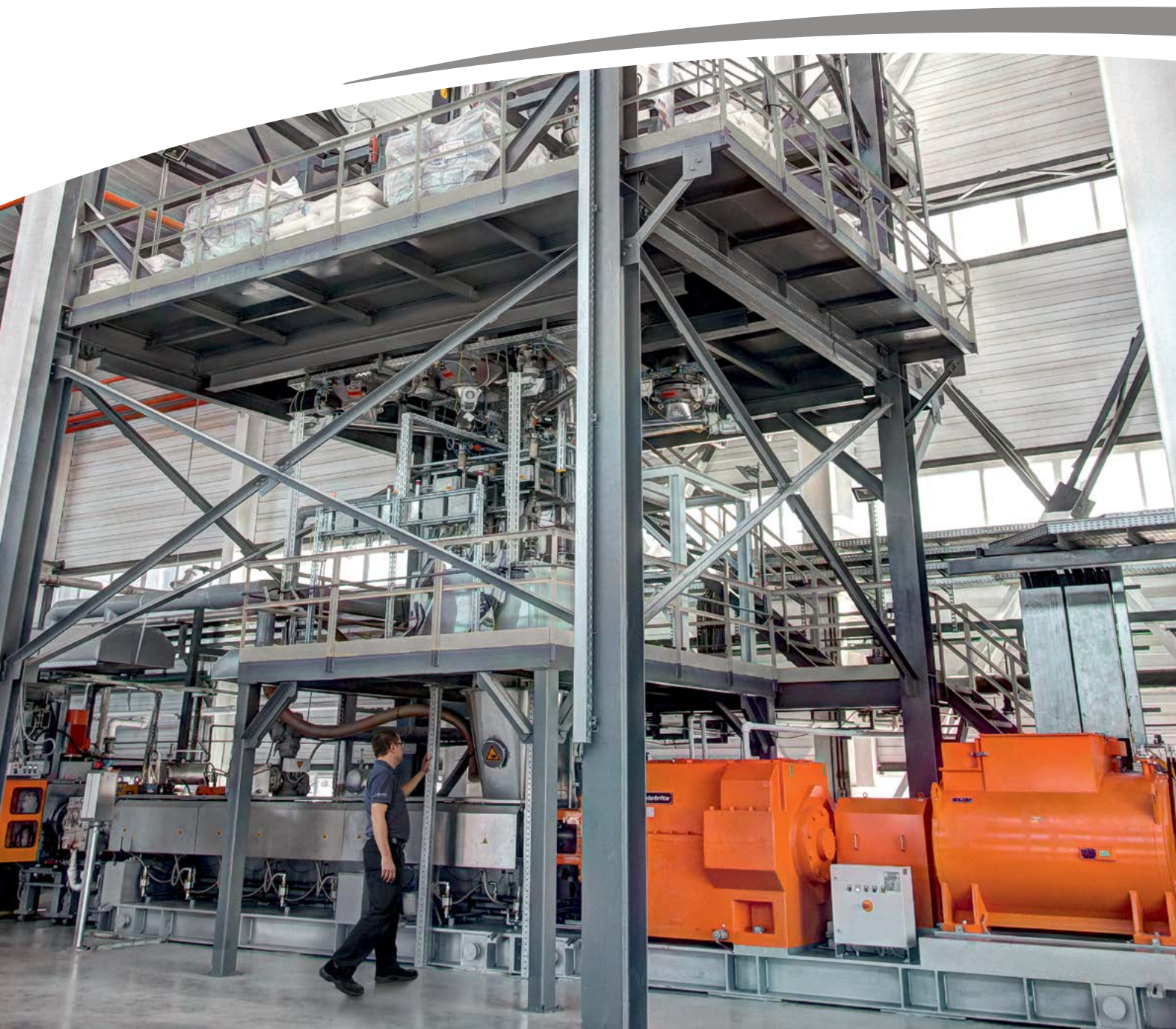

EXTRUSION TECHNOLOGY

With experience and passion



TWIN SCREW EXTRUDERS

Flexible and efficient

The alpha and omega for producing high-quality products from plastics or pharmaceuticals is a very good process technology. A core component for this is the co-rotating twin screw extruder. Due to its modular design, it is extremely flexible.

Leistriz has established itself as one of the worldwide leading producers of twin screw extruders. It is only possible to offer a fully developed product range through constant innovation and an open ear for the requirements of the users. For plastics processing, Leistriz offers the ideal combination of very high specific torque (15 Nm/cm³) and high volume (OD/ID = 1.66) with the ZSE MAXX series.

AT A GLANCE:

Twin screw extruder

- Usable for a multitude of processing applications
- Modular system: Screws and barrels individually configurable
- Self-cleaning screw geometry
- High productivity
- Continuous mode of operation – constant quality
- Optimum energy input

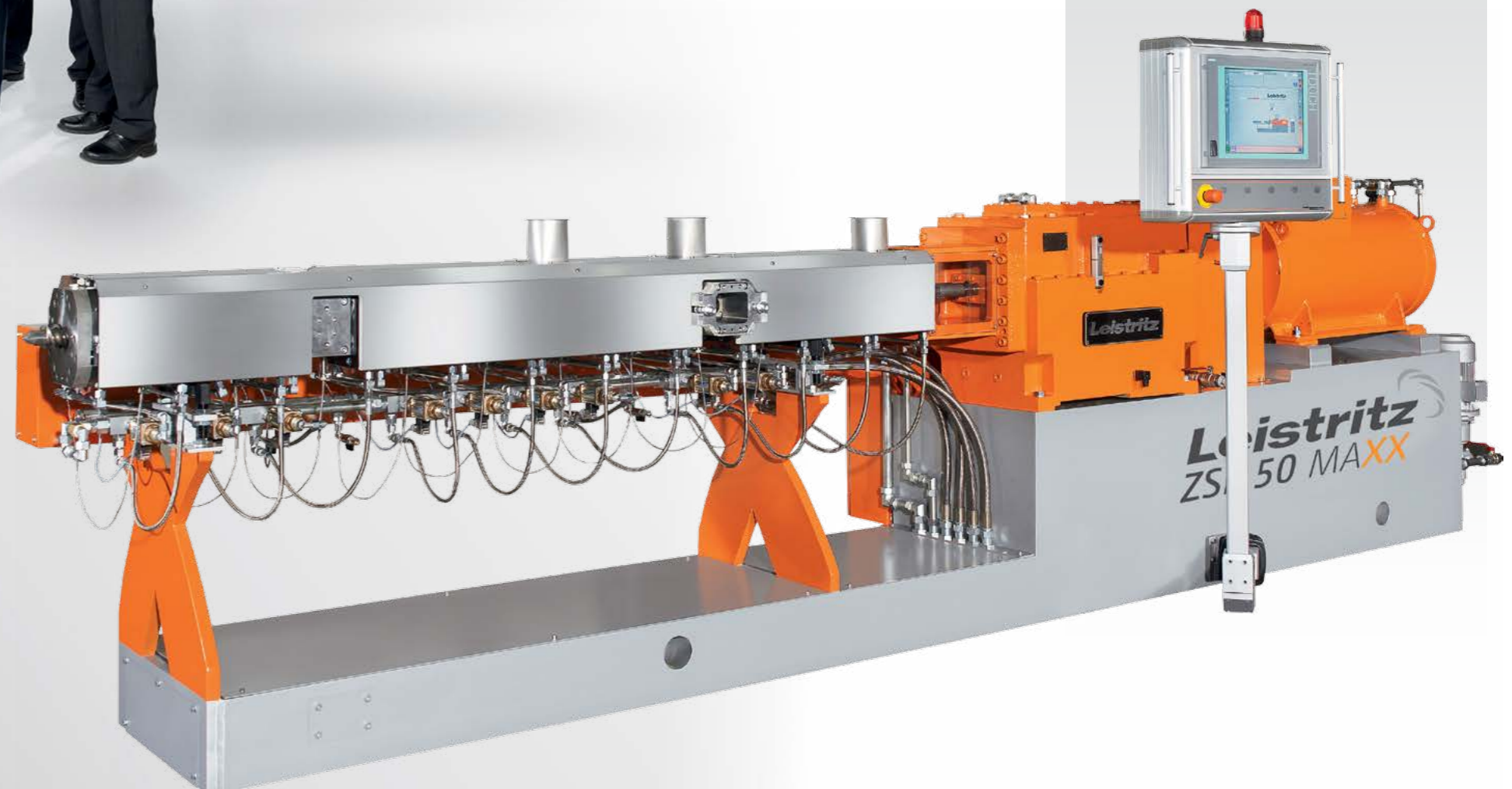

When screw pumps for pumping viscous masses were further developed at Leistriz nearly 80 years ago, it was barely imaginable that the present high-performance extruders would be the result. At the headquarters in Nuremberg/Germany, we conceive, design and produce individually laid out, co-rotating twin screw extruders and turn-key extrusion lines for the plastics and pharmaceutical industry. This, in combination with sophisticated process technology know-how, guarantees the high quality of our extruder lines. The heart of our extruders – the screws and barrels – are produced in the German Leistriz factories, without exception. The basis for this is the implementation of modern technologies, but particularly the nearly 200 employees worldwide – a dedicated team that stands behind the product. With branches in the USA, China and Singapore, sales offices in Italy and France and agents in all key markets, we have a global presence. Our customers profit from short communication paths and trusting professional cooperation.

PLASTICS PROCESSING

Compounding: Filling. Reinforcing. Improving.

The processing of plastics is one of the prime disciplines of Leistritz twin screw extruders. Typical compounding tasks are, among others, the reinforcement of polymers, improvement of their dimensional stability and tensile strength, impact-resistance modification of thermoplastic materials, production

of polymer blends. Diverse incorporation options for filler and reinforcement materials into the polymer matrix are possible and lead to new material properties, which are used in a multitude of applications. Leistritz ZSE MAXX twin screw extruders are an optimum choice for these.



Example of a customized extrusion line

RESULTS WITH ZSE MAXX:

- Enormous throughput increase with constant quality
- Energy saving of up to 20% due to higher utilization of drive power
- Maximum throughputs, even with processes that are shear-sensitive

Application example: Incorporation of glass fibers (40%) into polycarbonate (60%)

Particularly with temperature-sensitive processes, where gentle energy input is necessary, the combination of high volume (OD/ID = 1.66) and high torque (15.0 Nm/cm³) of the Leistritz ZSE MAXX technology can facilitate disproportionately high throughputs. Due to the fact that the polycarbonate, which is sensitive to shearing, has not yet reached the thermal limit in this process, the process can run at a higher screw speed with the use of a ZSE MAXX extruder.

» The compounding of thermoplastics is one of the main application areas of Leistritz twin screw extruders. «

More information can be found in the „Compounding“ brochure.

MASTERBATCH PRODUCTION

The grain of difference

Plastic pellets with a share of up to 85 weight-% of pigments, additives or fillers, are called masterbatches. The main component of a masterbatch line is the co-rotating twin screw extruder: It takes over the functions of homogenization and dispersion (splitting of the agglomerates), wetting and distribution of the pigments/additives/fillers in the polymer matrix. The production of masterbatches in the extrusion process depends particularly on the optimum incorporation of the additives into the polymer matrix. The fine, powdery base material often tends to agglomerate and therefore is difficult to process. In later work steps, such as injection molding, film or fiber production, these are added to the raw polymer for coloring or for targeted modification of other properties.

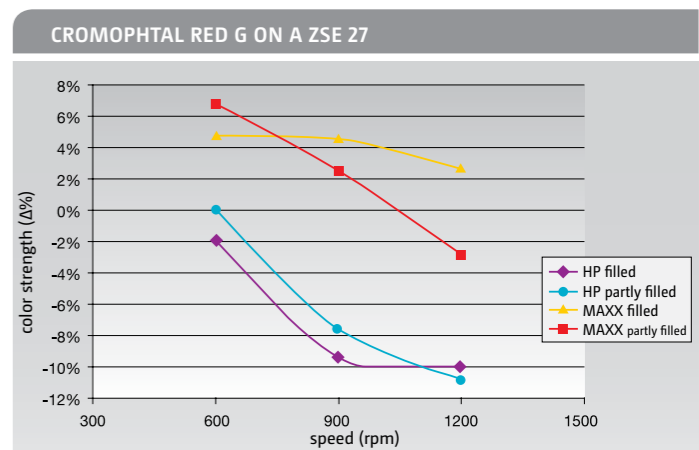

Application example: Production of a color masterbatch with Cromophtal Red G

The production has been compared here with two different Leistritz extruder series : a ZSE 27 MAXX (OD/ID = 1.66) and the predecessor model ZSE 27 HP (OD/ID = 1.5)



Example of a masterbatch line: ZSE 27 MAXX with strand pelletizing

RESULTS WITH ZSE MAXX:

- Quality of the produced masterbatch above the industrial standard
- Outstanding color strength (+ 6-8%)
- Significantly less agglomeration
- Good wetting and less compacting in the melting zone

More information can be found in the „Masterbatch“ brochure.

DIRECT EXTRUSION

Efficient and gentle processing

Direct extrusion or inline compounding offers the option of producing extrusion products particularly efficiently by combining various process steps. The intermediate step of pellet production is omitted and the extruder is used for material processing and shaping of the extrudate. By using according

downstream equipment, films, sheets, injection-molded parts or pipes can be directly produced. With direct extrusion, the product is spared from a second energy stress, which, in addition to the economic benefit, also often results in improved mechanical and optical properties of the end product.



THE BENEFITS:

- Pelletizing step is omitted
- Single stressing of the polymer through temperature and shear
- Valuable formulation know-how stays at one source
- Flexible production and product planning possible
- Process facilitates energy savings

Example of a PET film line: two ZSE MAXX twin screw extruders as the main component for recycling of virgin materials, as well as co-extruder for virgin materials

More information can be found in the „Film Extrusion“ brochure.

PHARMA EXTRUSION

Continuous processing of pharmaceutical masses

» *Leistritz with its lines in GMP design is the market leader in the demanding field of pharmaceutical extrusion.* «

In the past three decades, extrusion technology has become an interesting alternative for the development of pharmaceuticals such as pellets, tablets or transdermal systems. Pharma extrusion can generally be sub-categorized into hot melt extrusion and wet extrusion. In wet extrusion, the powdered components, such as active ingredients and auxiliary substances, are mixed while adding a pelletizing fluid and are discharged via a die as strands or in an open form. Subsequently, they are shaped into pellets. In contrast, with melt extrusion, the carrier substance (polymer) is processed above the glass transition temperature in order to evenly disperse the active ingredient in the polymer. By subsequently cooling down the melt, a „solid dispersion“ is generated with the improved release of active ingredients. This can take place through a chill roll or a cooling conveyor belt. Alternatively, the melt can be shaped into pellets with a defined mass and shape via die face pelletizing.

THE EXTRUSION PROCESS IS SUITABLE FOR:

- Integrating an API into a matrix (e.g. wax, cellulose, starch...)
- Pelletizing of a tablet premix
- Compounding of antibacterial TPU premixes
- Removing volatile components from a formulation
- Coating for transdermal applications
- Implementation of various dosage forms
- Reactive extrusion



The pharma extruders in GMP design from Leistritz fulfill strict clean room conditions

More information can be found in the „Pharma Extrusion“ brochure.

AUTOMATION TECHNOLOGY

Controlling and regulating

Everything comes together in the control unit. The philosophy of the Leistritz process and control technology: The extruder and all conventional upstream and down equipment that is necessary for a compounding process are integrated into one visualization and operating panel. It does not matter whether it involves monitoring gravimetric feeders, underwater pelletizers

or controlling a melt pump. Depending on the customer requirements, there are various systems available based on Siemens hardware, which are individually programmed by Leistritz. All quality-relevant process parameters are displayed, monitored and documented. BUS systems facilitate communication between all line components.

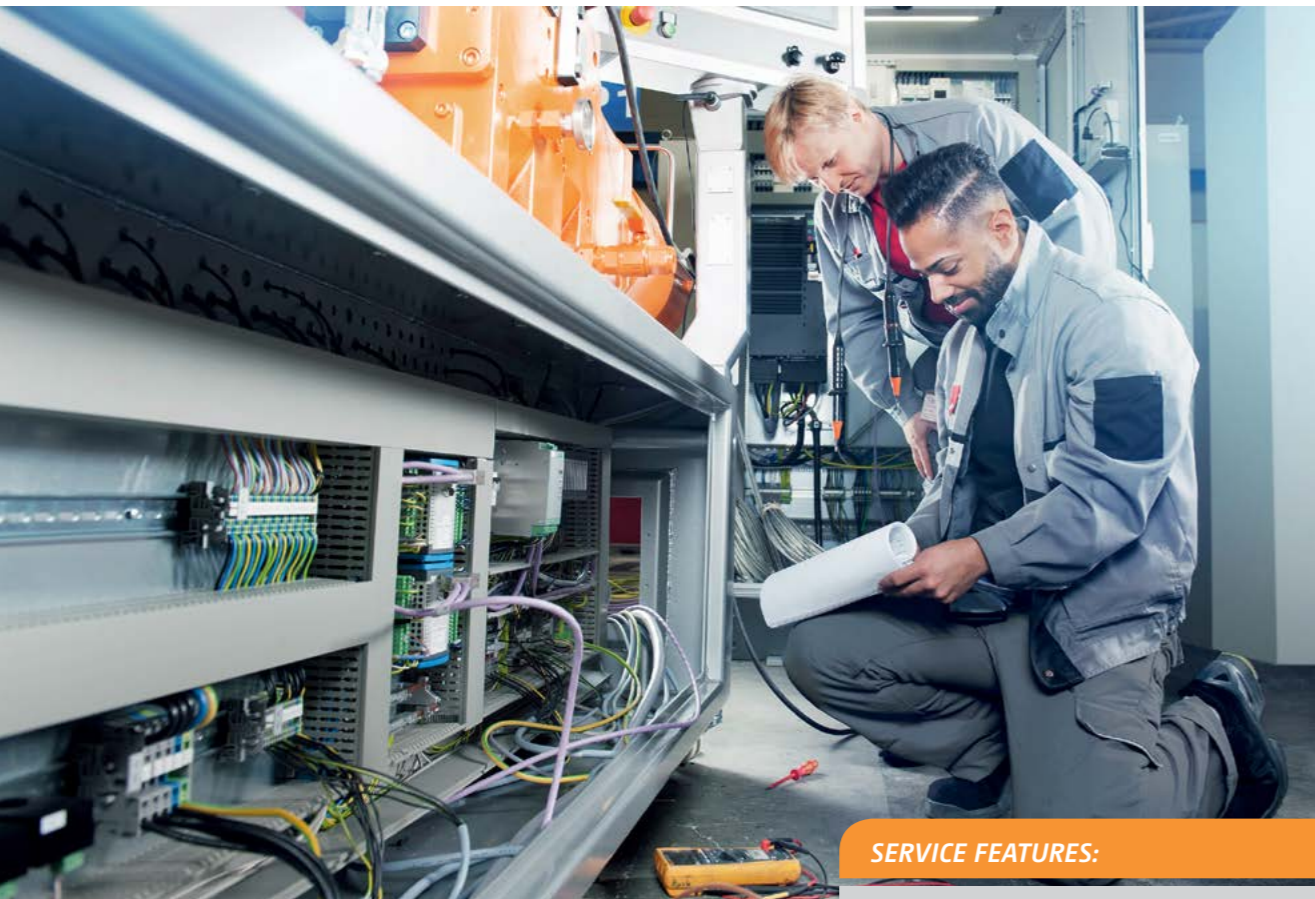

SERVICE FEATURES:

- Electrical planning of the complete extrusion line
- Integration of all upstream and downstream line components
- Optimum control and monitoring of all extruder components
- Use of Siemens hardware guarantees a huge support network
- Worldwide spare parts service
- Remote servicing

More information can be found in the „Automation“ brochure.



PROCESS SECTION

Modular screw and barrel system

Screws, shafts and barrels are the heart of an extruder. Leistritz offers an extensive variety of screw geometries for an almost endless number of variations. Generally, there are conveying, kneading and mixing elements. The competence of the Leistritz processing experts enables them to create an optimum screw design for the respective application.

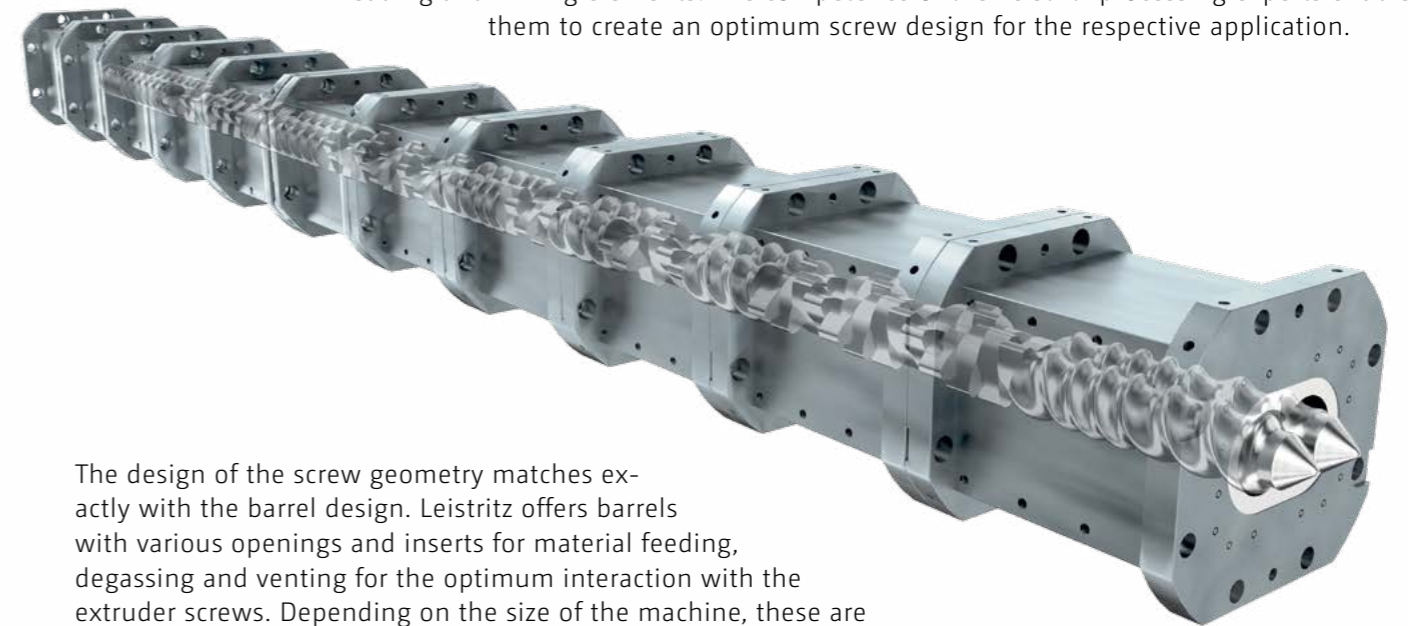

The design of the screw geometry matches exactly with the barrel design. Leistritz offers barrels with various openings and inserts for material feeding, degassing and venting for the optimum interaction with the extruder screws. Depending on the size of the machine, these are either connected via flanges or with internal tie rods.

More information can be found in the „ZSE MAXX“ brochure.

ZSE MAXX SERIES

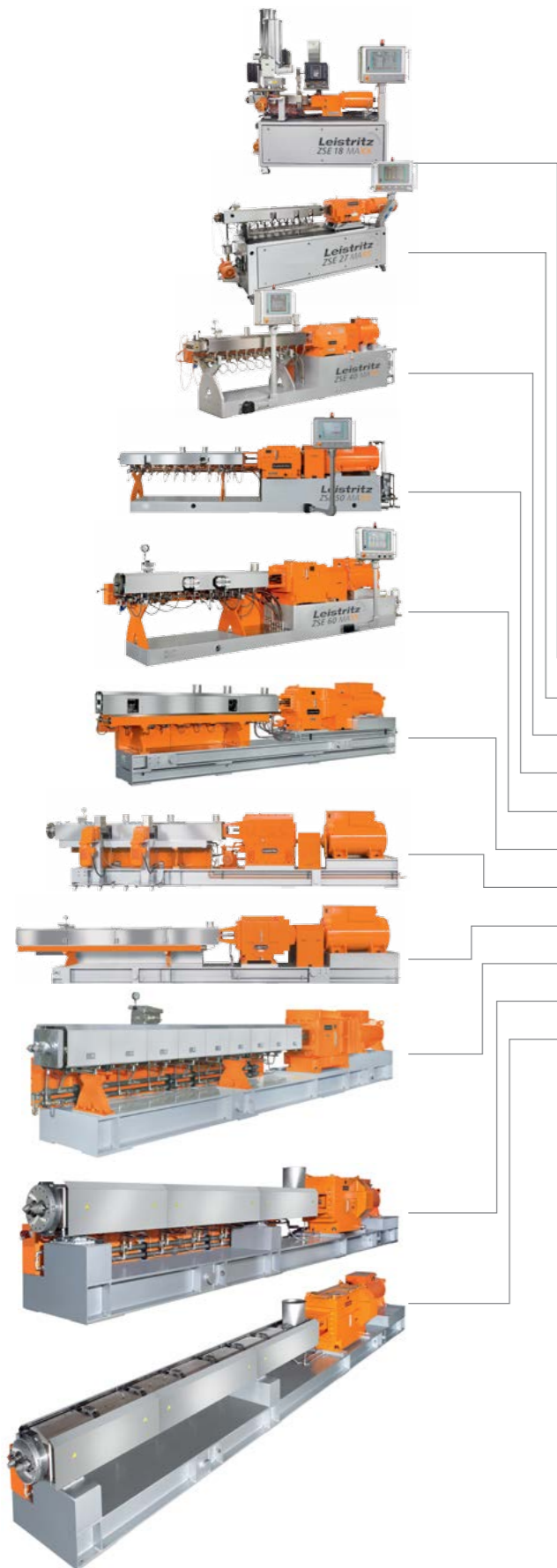

These features make the ZSE MAXX extruders so successful on the market:

- **maXXvolume**
increased free volume in the screw (OD/ID = 1.66)
- **maXXshaft**
very high total torque due to patented shaft-hub connection
- **maXXcooling**
up to 30% improved cooling by means of optimized flow of the liquid coolant through the barrel
- **maXXtorque**
very high specific torque (15.0 Nm/cm³)

Type ZSE MAXX	Screw Diameter OD (mm)	OD/ID	Spec. total torque (Nm/cm ³) up to max.
18	18.5	1.66	11.0
27	28.3	1.66	12.5
40	41.4	1.66	15.0
50	51.0	1.66	15.0
60	61.6	1.66	15.0
75	77.0	1.66	15.0
87	89.4	1.66	15.0
110	113.1	1.66	15.0
135	138.7	1.66	15.0
160	159.9	1.66	15.0
180	178.8	1.66	15.0

A very high specific torque (15,0 Nm/cm³) and a high volume (OD/ID = 1.66) in ONE extruder is what has distinguished the ZSE MAXX twin screw extruders on the market for the past decade. The enormous adaptability of the ZSE MAXX series provides the user with a processing advantage: A large range of processes can be covered with one machine. While previously, a choice needed to be made between a high-volume or high-torque machine, now virtually anything can be processed on a ZSE MAXX extruder.

More information can be found in the „ZSE MAXX“ brochure.

PHARMA EXTRUDERS

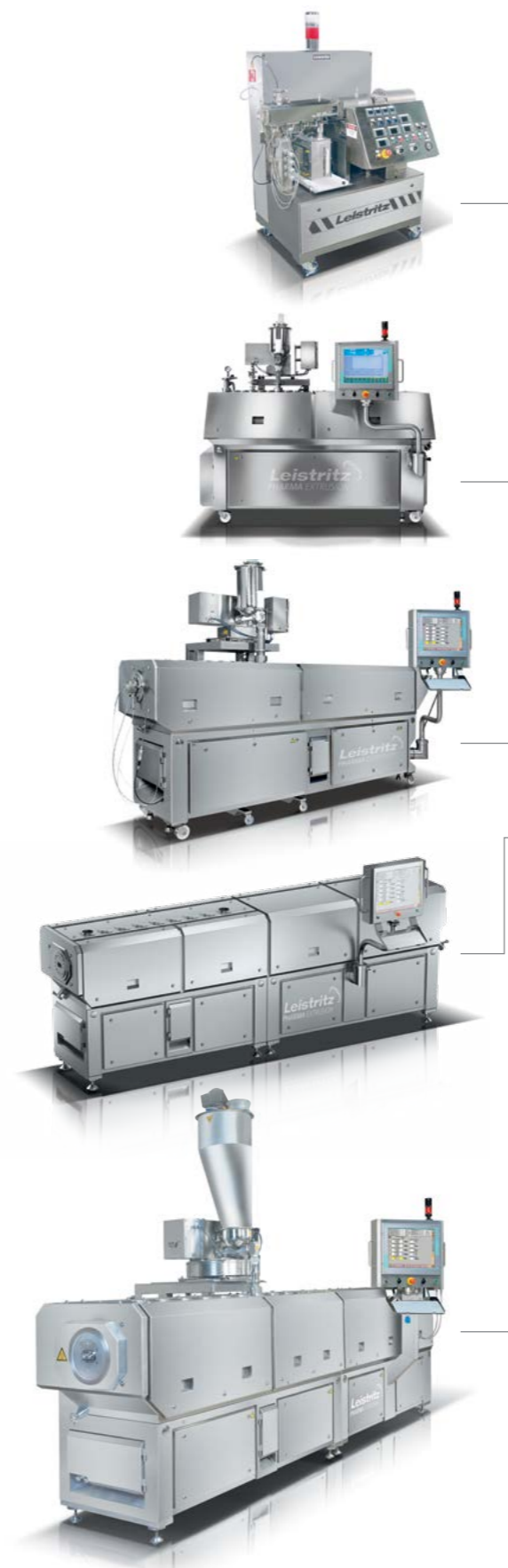

Leistriz offers a series of co-rotating extruders and relevant auxiliary equipment in GMP design for the specific requirements of the pharmaceutical industry. Extruders for pharmaceutical applications are not only distinguished by purely visible features, such as the usage of stainless steel. This machine generation provides everything that complies with the GMP requirements of the pharmaceutical industry including special fittings, material combinations, surface textures and increased documentation for qualification.

Type	Screw Diameter (mm)	Torque Screws (Nm)	Screw Speed (rpm)	Drive Power (kW)
NANO 16	16	42	500	2.24
ZSE 18 HP-PH	18	71	500 & 1,200	3.9
ZSE 27 HP-PH	27	268	500 & 1,200	15
ZSE 40 HP-PH	40	830	400	37
ZSE 50 HP-PH	50	1,570	400	70

» Leistriz – pioneer in pharmaceutical extrusion. Since the mid 1980's we have been delivering extruders to the pharmaceutical industry. «

More information can be found in the „Pharma Extrusion“ brochure.



ENGINEERING SERVICES

Know-how from professionals

» The planning and construction of a complete extrusion line is a project that must be precisely tailored to the customer's requirements. After all, our extruders are also not „off the peg“. «



As a system supplier, we guarantee a high level of process engineering expertise, an integral approach and not least, a co-operation based on trust and partnership. When it comes to turnkey solutions, we act with passion and know-how as advisors, planners, site managers, interface coordinators and trainers. It is our task to assist our customers during every phase of the project as a reliable partner – from conception and development right up to realization and commissioning.

Example of a major project: 3D visualization of a polymerization line

SERVICE WORLD

Customized customer care & consulting

The twin screw extruders by Leistritz are among the leading machines in the world in the plastics and pharmaceuticals market. They must satisfy the highest production and quality requirements every day. One of the formulas to stand one's ground in the tough competition is to work in an efficient and economical manner. Be reassured by our technical support with its decades of experience in dealing with extruders and extrusion lines. Our team is active around the world for you – competent and solution-oriented. They make sure that your technology always functions optimally and the work processes coordinate perfectly with one another.

OUR SERVICE OFFERS:

- Preventative maintenance
- Modernization/upgrading of extrusion lines
- Assembling/commissioning
- Original spare parts
- Trials in our labs in Nuremberg (Germany), Somerville (USA) and Taicang (China)
- Consultancy in the fields of process and electrical engineering consulting
- Training sessions
- Leistritz Service Hotline: +49 911 / 4306-444

More information can be found in the „Service“ brochure.



RESEARCH & DEVELOPMENT

Testing. Inspecting. Optimizing.

The global cooperation with institutions, universities and development partners is an important part of the Leistritz philosophy. Through our research and development projects, we are working on the future and expanding our process engineering and machine know-how. Not only we, but also our customers, profit from this lead in knowledge.

In the area of research, development and sample production, the flexible Leistritz laboratory extruders are in high demand. They are convincing due to their compact design requiring only little space. The user gets the flexibility of an extruder, which can either run in pure laboratory operation, as well as produce small batches. The results that are achieved with these machines are the key to „scaling up“ to larger production machines.



The ZSE 27 iMAXXX – the ideal laboratory extruder: space-saving and efficient!

» Leistritz extruders are used in more than 100 institutes worldwide. «



Process laboratory in Nuremberg/Germany

In-house, with our process labs in Nuremberg (Germany), Somerville (USA) and Taicang (China), we offer a production-related environment, in which our customers can put their product developments to the test. Processes are tested and optimized here on various Leistritz extruders. We even use these resources ourselves in order to work on new trends and extruder solutions. In the area of research, development and sample production, flexible machines with compact designs are required.

LEISTRITZ GROUP

One company – dynamic, innovative, reliable, collaborative

The special thing about Leistritz: It was founded in 1905 as a family enterprise. We are still an owner-operated company today, in which dynamic further development and innovative solutions count and values such as reliability and partnership are embodied.

With turbine blades for the aviation and aerospace industry, screw pumps for sectors such as oil and gas,

the chemical industry and shipbuilding, twin screw extruders for the plastics and pharmaceuticals industry, as well as tools/machine tools for the automotive industry and mechanical engineering, we offer an extremely wide range of solutions. The high level of expertise in products and technology has always been the basis of our success. We employ approx. 1,900 staff in the various locations worldwide.

» Four business units – one motion: rotation! «

TURBINE TECHNOLOGY
Blades for turbines and compressors



EXTRUSION TECHNOLOGY
Extruders and extrusion lines

PUMP TECHNOLOGY
Screw pumps and systems



PRODUCTION TECHNOLOGY
Machine tools, tools, tube technology

EXTRUSION TECHNOLOGY

Available for you all over the world

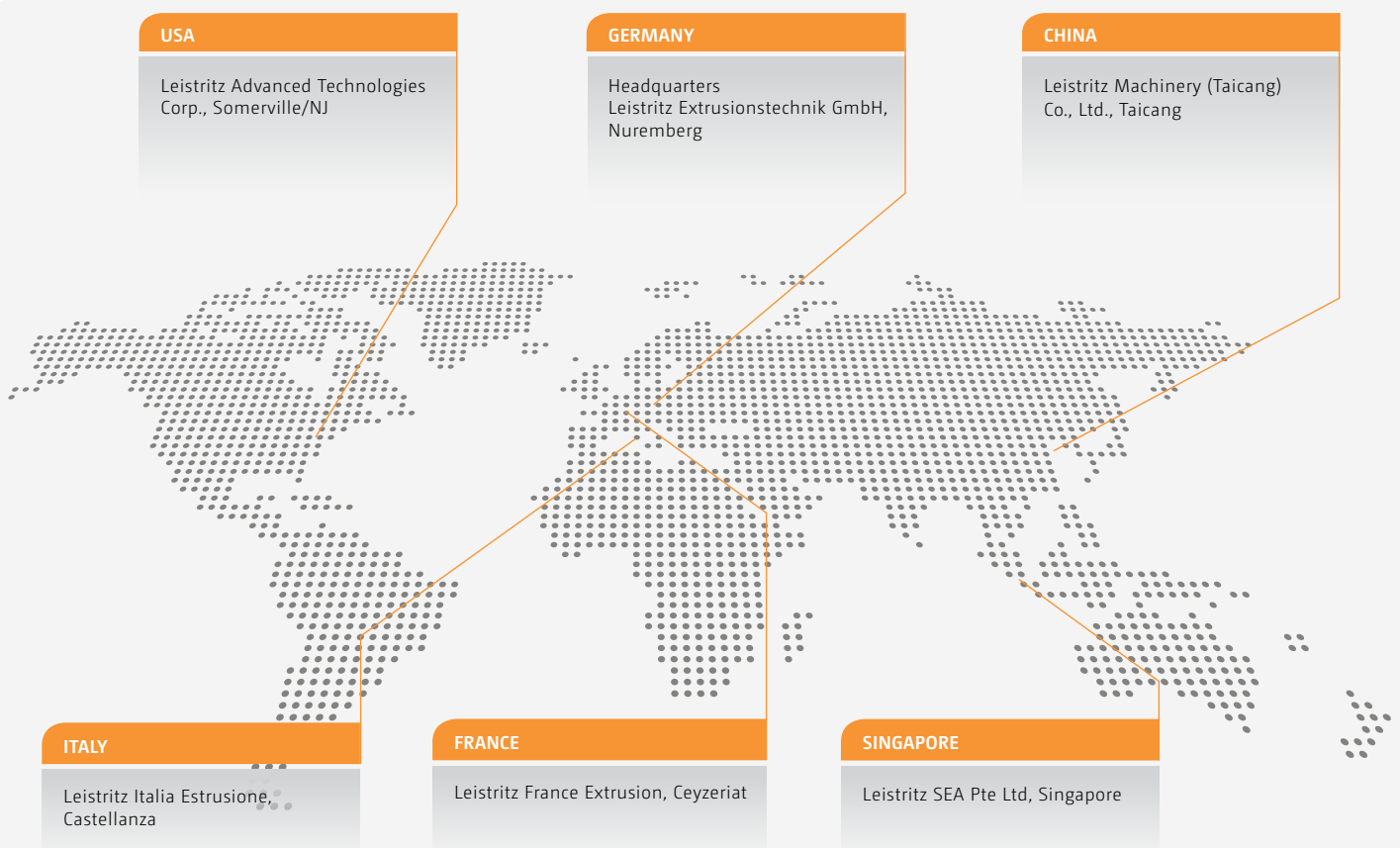

➤ Leistritz Extrusionstechnik GmbH | Markgrafenstraße 36-39 | 90459 Nuremberg | Germany
Tel.: +49 911 43 06 - 0 | Fax: +49 911 43 06 - 400 | extruder@leistritz.com